



## USING A 90° TRACK BEND

Used for non-linear drape effects or corners.

### STEP 1:

Insert pins into assembled track, using a hammer if fit is tight. Pins are made from 30mm lengths of 3mm rod. Cut using a hack saw or bolt cutters.

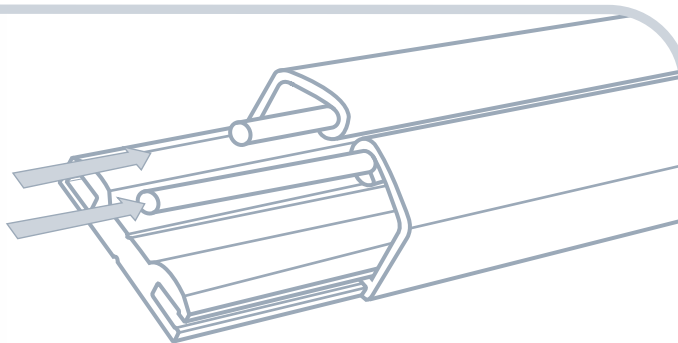

### STEP 2:

Slide base of supplied pre-bent track forward approximately 10 - 20mm.

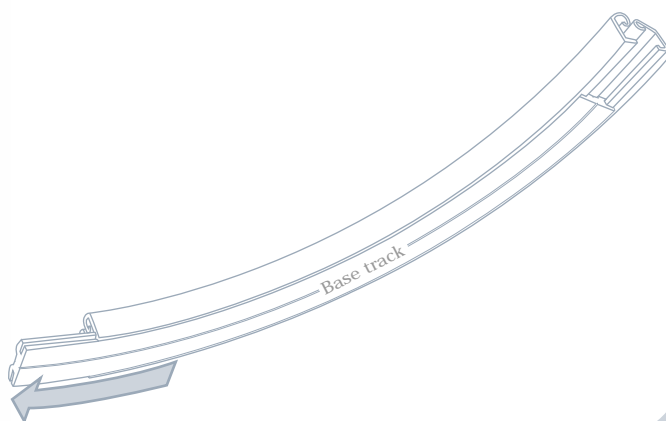

### STEP 3:

Slide track components into position. Tap track ends with hammer to secure.

